

Jaguar XK 140/150, MGA, Morgan, Triumph TR2 – TR3 and Others LED Tail Lights Installation Instructions

- 1) Refer to the parts list at the last page of these instructions and verify that the set is complete.

Note: These sets come in either positive (yellow ground wire) or negative (black ground wire) ground configuration. Check that you have the correct set before starting the installation.

Note: We recommend that the tail light functions be verified to operate correctly before installing the LEDs. If possible measure the voltage levels for the running and brake lights at the tail lights. They should be within a few 10ths of a volt compared to the battery voltage. If not you may have wiring issues that should be addressed.

Note: There is an aftermarket tail light lens that is shaped differently on the inside from the original lens. Check that the circuit boards fit inside your lenses. If they do not fit, the circuit board sides can be filed down to fit. Or replace with the original style lenses.

- 2) These LED tail light turn signals usually require an electronic flasher unit to work properly and are available at auto parts store. Make sure the electronic flasher has the same number of connectors as the original unit. Here is a list of suggested 3 pin flasher units:

CEC Industries EF33.

Bussmann 233.

These part numbers can be used for cross-referencing to other manufactures. *If your car is positive ground and the turn signals do not operate correctly then you may have to add LED load resistors to the tail light turn signals. They can be ordered from the Internet (www.v-leds.com), part #LR-650 for a pair. A positive ground electronic flasher is not available at this time.*

- 3) We suggest that you evaluate the condition of the tail light lens gaskets and if necessary order new ones before starting installation.
- 4) Remove the tail light lens and bulb.
- 5) Disconnect the three wires to the bulb holder.
- 6) Remove the chrome base plate from the plinth. This leaves the three wires hanging out of the rubber gasket from the plinth.

- 7) Drill out the two rivets securing the bulb holder to the chrome base plate (Fig.1). Remove the bulb holder. Save the bulb holder if you want to restore the tail light to its original state. The circuit board has two holes that line up with the rivet holes. We do not recommend using these holes to mount the circuit boards due to the screw heads possibly causing a short circuit on the boards. The circuit board sits on top of the lens gasket and is held in place by the lens.**
- 8) Pull the three wires back through the rubber gasket. Do not let the wires fall back into the plinth.**
- 9) Take three of the supplied bullet sleeves and push one on each wire.**
- 10) Take an LED circuit board and insert the three wires from the board through the chrome base plate holes and rubber gasket that held the original wires.**
- 11) Connect the new wires to the bullet sleeves for each wire according to the supplied wiring diagram. Make sure the connections are tight and secure.**
- 12) Push the wires with the bullet sleeves into the plinth so that the rubber gasket fits to the plinth.**
- 13) Mount the chrome base plate back onto the plinth.**
- 14) Place the rubber lens gasket on the base, then put the circuit board on top of the gasket. Fit the lens over the circuit board and attach with the screws.**
- 15) Repeat the above process for the other tail light assembly.**

Fig. 1

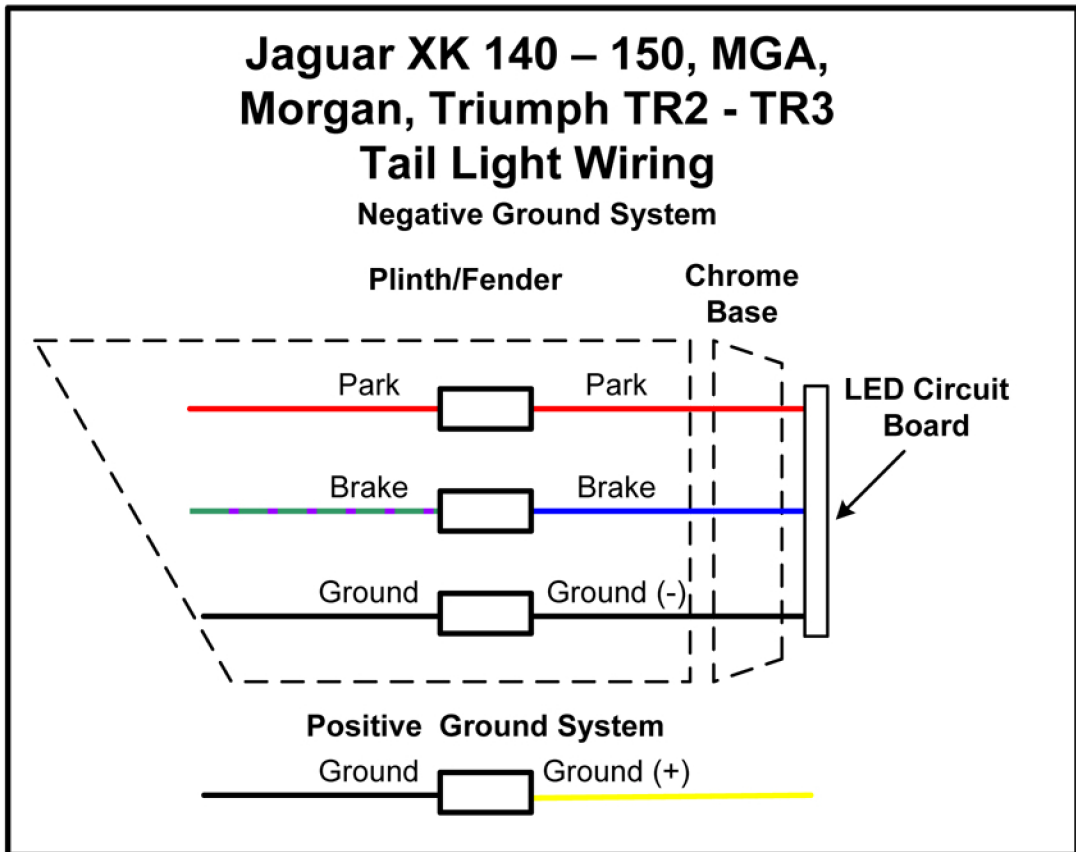

Parts List

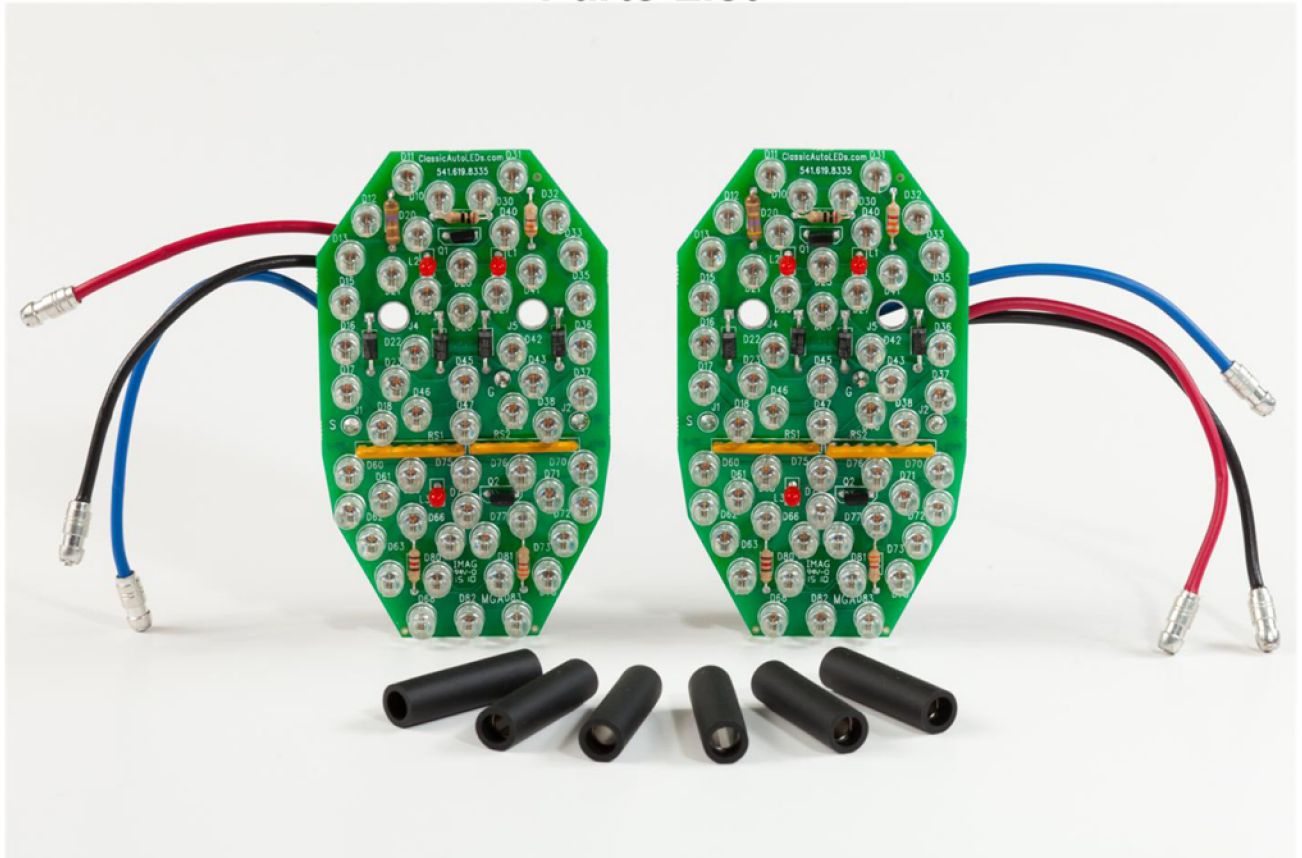

Set Contents (Negative Ground Set Shown)

	Description	Qty
1	Single bullet sleeve connector	6
2	Brake/parking light circuit board	2
3	Installation instruction and wiring diagram	1